

Laboratory testing of SFRC samples proposed for tunnel lining segments

M.Hilar

3G Consulting Engineers s.r.o. and FCE CTU in Prague, Prague, Czech Republic

J. Vodička, J. Krátký & V. Ráček

FCE CTU in Prague, Prague, Czech Republic

ABSTRACT: The utilisation of steel fibre reinforced concrete (SFRC) instead of traditional reinforced concrete (RC) for some structures can bring many advantages. All advantages are given by properties of SFRC, partly by strength properties, mainly by strain characteristics. An appropriate concrete structure for utilisation of SFRC can be tunnel lining generated from precast concrete segments. The loading of precast concrete segments, namely during installation of segments, leads often to mechanical damage of joints. The utilisation of SFRC for tunnel segments can reduce damage of joints, which is one of many advantages of the SFRC utilisation for tunnel segments.

The main goal is to show approach to replacement of used material (i.e. approach from the design of concrete composition to results of experimental testing of key segment generated from SFRC without traditional rebars). Properties of SFRC were verified on standard samples. Uniaxial strength was verified on cubes (150 mm), flexural strength was verified on beams (700 x 150 x 150 mm). Two dosages of steel fibres (50 kg/m³ and 70 kg/m³) together with two types of steel fibres (Dramix and Tri Treg) were verified by laboratory testing to achieve material stability during transport, tunnel lining installation, and during its lifetime, mainly with regards to given thickness of segments 250 mm (construction of Prague metro line A extension).

The compression of a key segment generated from SFRC with fibre dosage 50 kg/m³ is described in this paper (this test of segment was realised the first), all other test of SFRC segment will be described in other papers later. Results of compression test of the SFRC key segment are compared to results of the same test of RC segment, which was realised as well.

1 RESULTS OF MATERIAL TESTING

The concrete mix with steel fibres Dramix with fibre dosage $m_f = 50 \text{ kg/m}^3$ was proposed and verified for tested key segment. The first of all compression strength was verified on cubes with size 150 mm according to the Czech standard CSN EN 12390-3 (see Tab. 1). The average cube strength $f_{c, mc, cub} = 67.3 \text{ MPa}$ is resulting from Tab. 1.

The following parameters can be derived from Tab.1:

standard deviation of 6 samples:

$$s_6 \approx 2,58 \text{ MPa}$$

standard variance:

$$\Delta f_{kc, cub, 3} = 1.48 \cdot 2.85 = 4.25 \text{ MPa}$$

Table 1. Compression strength tested on SFRC cubes

Sample	Dimensions			Weight [g]	Unit weight [kg/m ³]	Uniaxial force [kN]	$f_{c,i}$ [MPa]
	b [mm]	h [mm]	l [mm]				
4	149,0	147,6	150,4	7968	2409	1520	69,1
5	148,5	150,8	150,5	8209	2436	1437	64,2
6	151,0	150,5	151,2	8285	2411	1634	71,9
10	150,5	155,9	150,6	8214	2325	1565	66,7
11	147,7	154,0	150,3	8156	2386	1474	64,8
12	150,2	155,3	150,7	8359	2378	1561	66,9
Average value:					2391	1532	67,3

cube strength:

$$f_{fc, kc, cub} = 67.3 - 4.25 = 63.05 \text{ MPa}$$

The compressive strength class of the SFRC samples was derived from the table 2.7.1b from TP-FC 1-1 (i.e. the closest lower value of characteristic cube strength:

$$f_{fc, kc, cub} = 60 \text{ MPa} < 63.05 \text{ MPa}$$

The SFRC material can be marked as: **FC** $f_{fc, kc, cyl} / f_{fc, kc, cub} = \text{FC } 55/60$

Ratio 0.9 of cylindrical and cube strength was considered.

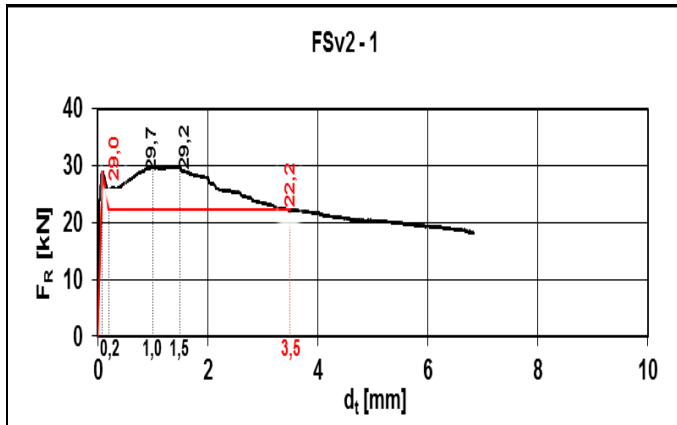

Figure 1. Stress-strain diagram

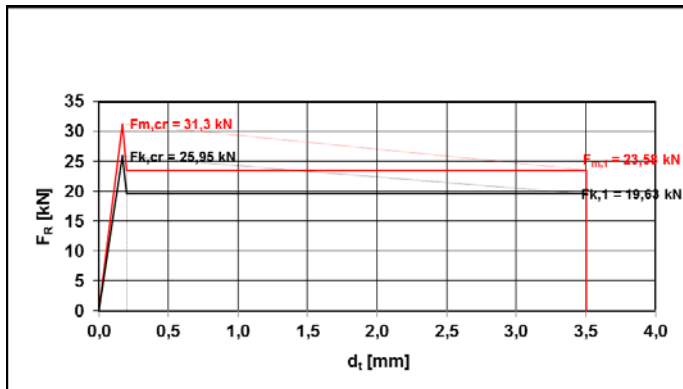

Figure 2. Simplified idealised stress-strain diagrams: average, characteristic

Four point bending tests of SFRC beams were executed to get tension strength of the material. The tests were realised in Klokner testing laboratory of the Czech Technical University (CTU) in Prague and results of stress-strain diagrams ($F_R - \delta_{ti}$) were determined for agreed deflections δ_{ti} of standard beam for all six specimens.

Graphical output of stress-strain diagrams ($F_R - \delta_{ti}$) is presented on Fig. 1. Idealised diagram is also presented in Fig.1 (red colour) to simplify derivation of SFRC strength for two limit deflections:

a) limit for macrocracks $\delta_{t, cr}$

b) agreed limit deflection $\delta_{t, 3.5} = 3.5 \text{ mm}$

Strength evaluation of all tested beams is presented in Fig. 2:

1) Average strength of beams on macrocrack limit: $F_{Rm, cr} = 31.3 \text{ kN}$,

with standard deviation $s_6 = 3.64 \text{ kN}$

Standard variance of all six beams:

$$\Delta F_{Rk, 6} = 1.48 \cdot 3.64 \approx 5.4 \text{ kN, therefore}$$

characteristic strength is:

$$F_{Rk, cr} = 31.3 - 5.4 = 25.9 \text{ kN}$$

2) Average strength of beam for limit deflection $\delta_{t, 3.5} = 3.5 \text{ mm}$: $F_{Rm, 1} = 23.6 \text{ kN}$

with standard deviation $s_6 = 2.7 \text{ kN}$

Standard variance of all six beams:

$$\Delta F_{Rk, 6} = 1.48 \cdot 2.7 = 4.0 \text{ kN, therefore}$$

characteristic strength is:

$$F_{Rk, eq, 1} = 23.6 - 4.0 = 19.6 \text{ kN}$$

Average and characteristic tensile strength of SFRC:

The following general formula is valid for standard four point bending test of beams:

$$M_E = \frac{1}{2} F_R \frac{l}{3} = F_R \frac{l}{6}$$

1) The bending moment on macrocrack limit $F_{Rm, cr} = 31.3 \text{ kN}$ is the following:

$$M_{m, cr} = 31.3 \cdot \frac{0.6}{6} = 3.13 \text{ kNm.}$$

The average tensile strength in bending based on quasilinearly elastic behaviour of beams is afterwards $f_{fc, tm, fe, cr} = 6 \cdot M_{m, cr} / bh^2 = 6 \cdot 3.13 / 0.15^3 \approx 5.56 \text{ MPa}$.

Similarly the following formula is valid for characteristic tensile strength in bending:

$$F_{Rk, cr} = 25.9 \text{ kN is } M_{k, cr} = 2.59 \text{ kNm}$$

Characteristic tensile strength in bending: $F_{fc, tk, fe, cr} = 6 \times 2.59 / 0.15^3 = 4.61 \text{ MPa}$.

Derived characteristic central tensile strength on macrocrack limit:

$$f_{fc, tk, cr} = f_{fc, tk, fe, cr} / 1.45 = 4.61 / 1.45 = 3.18 \text{ MPa}$$

Central tensile strength class of SFRC is according to Tab 2.7.2 TP FC 1-1 (Fig. 3):

$$f_{fc,tk} = 3.1 \text{ MPa}$$

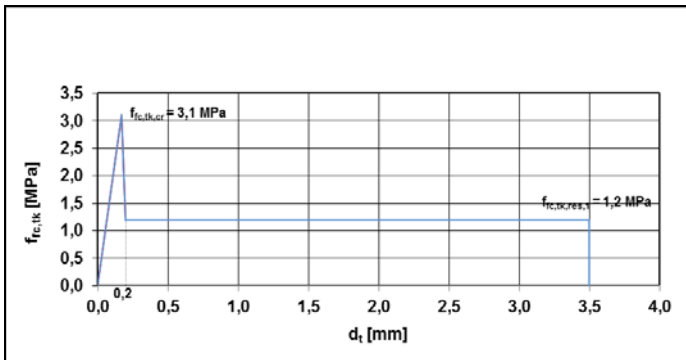

Figure 3. Example of stress-strain diagram ($f_{fc,tk} - \delta_{t,i}$) i.e. (char. Central tensile strength – deflection) using simplified diagram

2) The following values are valid after reaching of limit deflection $\delta_{t,1} = 3.5$ mm:

$$F_{m,1} = 23.6 \text{ kN}; M_{m,1} = 0.1 \times 23.6 = 2.36 \text{ kNm}; f_{fc, tm, eq, 1} \approx 2.2 \times 2.36 / 0.15^3 \approx 1.54 \text{ Mpa}$$

The derived equivalent characteristic strength of SFRC in central tension in $\delta_{t1} = 3.5$ mm (according to the TP FC 1-1, draft – February 2012)

$$f_{fc,tk,eq,1} = 2.2 M_{m,1} / bh^2 = 2.2 \cdot 1.963 / 0.15^3 = 1.28 \text{ MPa, where } M_{m,1} = 0.1 \cdot 19.63 = 1.963 \text{ kNm}$$

Strength class FC in central tension in $\delta_{t1} = 3.5$ mm (according to the 2.7.3 TP FC 1-1)

$$f_{fc, tk, res, 1} = 1.2 \text{ MPa}$$

Strength class FC in compression determined on cubes is: FC 55/60

Therefore full labelling of tested SFRC generated in Senec with 50 kg/m^3 of Dramix fibres is:

FC 55/60 – 3.1/1.2.

2 PRODUCTION OF KEY SEGMENT

Production of key segment generated from SFRC for testing is shown on Fig. 4.



Figure 4. Production of SFRC key segment for trstiny (a – casting; b – demoulding)

3 LOADING TEST OF KEY SEGMENT

Testing of both RC key segment and SFRC key segment was realised in Klokner laboratory of the Czech Technical University in Prague. Key segments were loaded by axial force to simulate pressure from rams located on the back part of the tunnelling shield (TBM technology) during its penetration into the ground (i.e. tunnel lining is loaded in longitudinal direction).

Values of acting force and corresponding values of deformations were continually recorded. Deformations were monitored by both potentiometers and tensometers located on the segment surface (see Fig. 5).

Key segments were placed on the testing machine. 9 mm thick plastic plate was placed on the upper part of the segments and steel plate 20 mm thick was placed over it. Both plates corresponded with dimensions and material of tunnelling shield rams.

The acting force was increased with 300 kN steps, the segment was unloaded to 90 kN between all loading steps.

- SFRC key segment - $F_{fc,u} = 7200\text{kN}$

B) RC SEGMENT

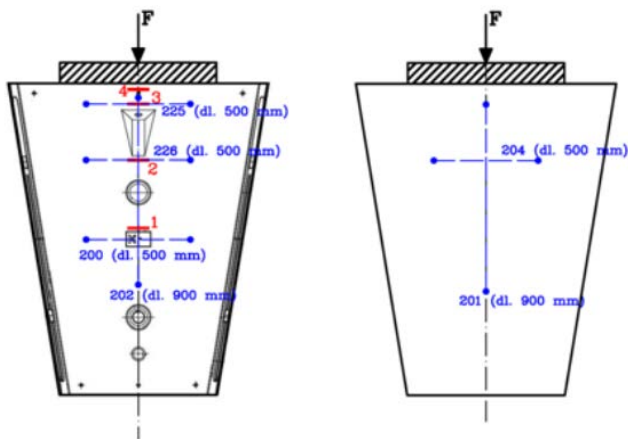

Figure 5. The test arrangement including locations of potentiometers and tensometers

Concrete	RC	SFRC
The first crack - force F_{cr} [kN]	3300	4200
Maximum reached force F_u [kN]	5868	cca 7200

Table 2. Comparison of resulting measured forces of compression test realised on two key segments with a different reinforcement

A) SFRC SEGMENT

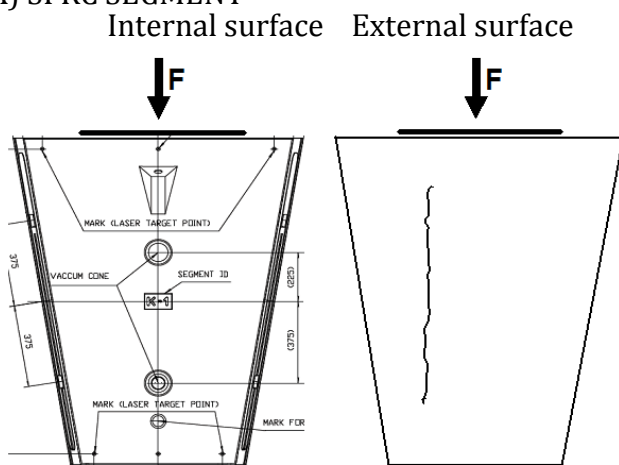

Figure 6. Record of macrocrack location - SFRC key segment - $F_{fc,cr} = 4200\text{kN}$

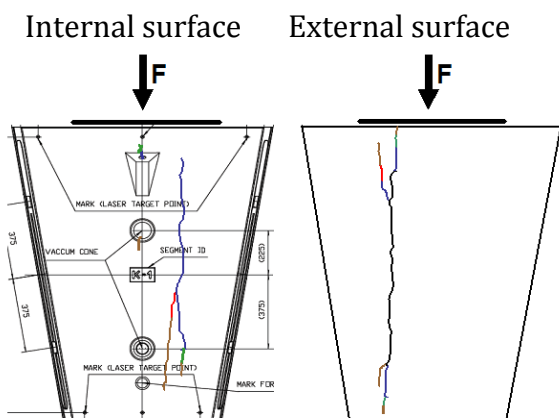

Figure 7. Record of macrocrack location under maximum load

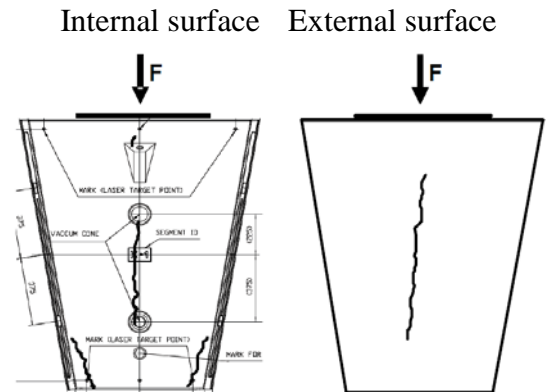

Figure 8. Record of macrocrack location - RC segment - $F_{fc,cr} = 3300\text{kN}$

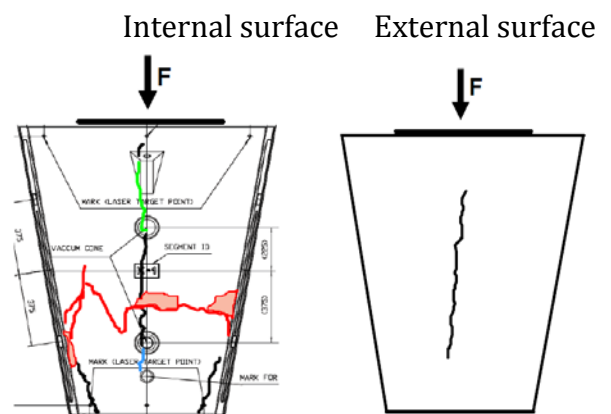

Figure 9. Record of macrocrack location under maximum load - RC segment - $F_{fc,u} = 5868\text{kN}$



Figure 10. Comparison of damaged key segments after reaching their capacity:

- a) RC segment
- b) SFRC segment

4 DISCUSSION OF RESULTS

The following findings can be presented from results of realised SFRC testing:

- Results of SFRC material testing due to unit weight of cast SFRC specimens show acceptable homogeneity of the material. Similarly variance of compression strength and bending tensile strength is within acceptable limits.
- The SFRC material can be labelled to strength class according to FC TP - 1 part 1.

- The realised testing of key segment proved better behaviour of SFRC segment in comparison to RC segment – later generation and propagation of cracks, manner of failure and higher load leading to the failure.

force of tunnelling shield on Prague metro line A extension $F_E = 2430$ kN.

Financial support of the research grants GAČR P104/10/2023, TAČR TA01011816 and TA01031840 is gratefully acknowledged.

5 CONCLUSION

The tested SFRC key segment showed in both load cases (macrocrack generation and compression capacity) higher values, which were about 25% than in case of RC segment.

The load value of the first macrocrack generation is namely important, because it correspond with SLS (serviceability limit state).

Testing results showed about 3 times higher capacity in comparison to required maximum axial

REFERENCE

- [1] TP FC 1-1 Technical conditions 1: SFRC – Part 1 Testing of SFRC – Evaluation of destructive tests and determination of stress-strain diagram of SFRC for the design of concrete structures (Faculty of Civil Engineering, Czech Technical University, Department of Concrete Structures, Prague 2007)
- [2] Vokáč M., Bouška P.: Experimental testing of precast segments for metro V.A tunnel lining - Segment K from SFRC; CTU, Klokner laboratory; Prague; 2011